

DATASHEET

PART NUMBER

WES1615-10

Wescon 1615 Quick Change Collet Chuck - Size #10 (0.1935in)

Short series for use in right angle drill motors with our model 1760 chuck

WEBSITE

<https://www.wesconusa.com/products/WES1615-10>



* The image represents the general look of the series. Actual product may vary based on options selected.

SPECIFICATIONS

Mount Type	Quick Change
Chuck Type	Collet Chuck
Size	#10 (0.1935in)
Country of Origin	USA

ADDITIONAL IMAGES AND DRAWINGS



Image 1

WES1615 Series Quick Change Collet Chuck

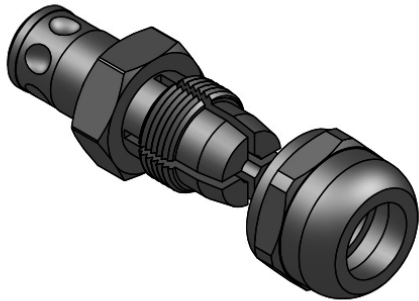
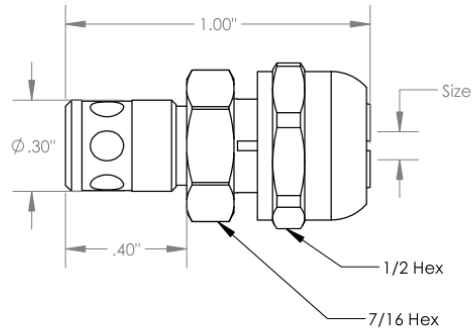
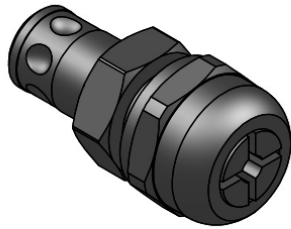

Minimum Size: 0.0700in
Maximum Size: 0.2570in

Order as P/N WES1615-(SIZE)
See wesconusa.com for full list of available sizes and part numbers.
Custom size available upon request.

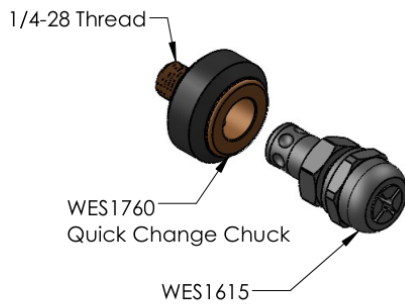

Notes from our Engineering Team

- Adapts straight shank tools to be used in quick-change system.
- Use with the WES1760 to connect quick-change tooling to 1/4-28 threaded drill motors.



Part Number

WES1615

Do not modify, copy, distribute, or reproduce this drawing without prior written authorization.

© 2025 Wescon Industries Inc.
601 Century Plaza Dr. Houston, TX 77073, US
www.wesconusa.com

Quick Change Collet Chuck

Revision 03

All dimensions are in Inches

Information in this drawing is provided for reference only

Image 2