

DATASHEET

PART NUMBER

WES1750-EXL

Wescon 1750 Quick Change Chuck - Extended

Standard series quick change chuck. Fits most drill motors for reliable and fast bit changes.

WEBSITE

<https://www.wesconusa.com/products/WES1750-EXL>



SPECIFICATIONS

Mount Type	Female Thread
Chuck Type	Quick Change
Thread Size	1/2-20
Cap Type	Extended
Country of Origin	USA

ADDITIONAL IMAGES AND DRAWINGS

WES1750 Series Quick Change Chuck

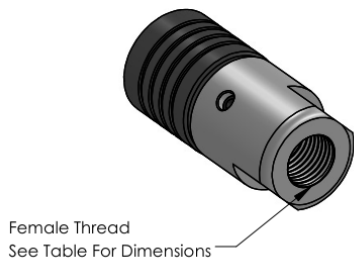
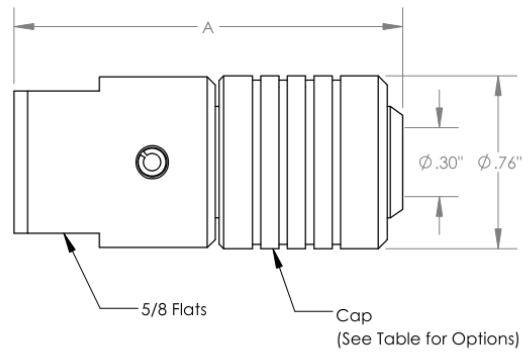
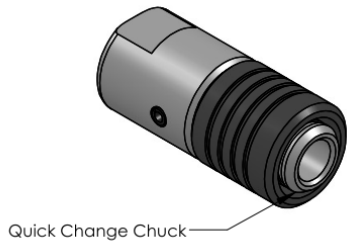

Part Number	A (OAL)	Cap	Thread
WES1750	1.71"	Standard Ridged Cap	3/8-24
WES1750-SC	1.71"	Smooth Cap	3/8-24
WES1750-EXL	2.40"	Standard Ridged Cap	1/2-20

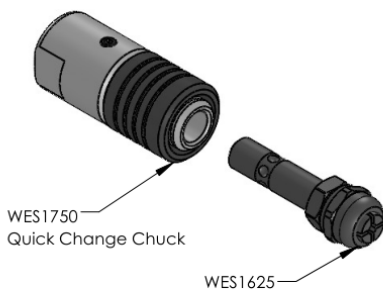

Notes from our Engineering Team

- Mounts directly to threaded drill motors to provide an instant quick-change connection.
- Compatible with quick-change shank tools and WES1625 collet for straight shank tools.



Part Number **WES1750 Series**

Do not modify, copy, distribute, or reproduce this drawing without prior written authorization.

© 2025 Wescon Industries Inc.
601 Century Plaza Dr. Houston, TX 77073, US
www.wesconusa.com

Quick Change Chuck

Revision 03 All dimensions are in Inches Information in this drawing is provided for reference only

Image 1