

DATASHEET

PART NUMBER

WES396-EN-TF

**Wescon 396 Microstop - 1/4-28 - 1/2" Cutter
Capacity - External Nylon Foot**

SMALL CAPACITY / TIGHT SPACE APPLICATIONS

WEBSITE

<https://www.wesconusa.com/products/WES396-EN-TF>



* The image represents the general look of the series. Actual product may vary based on options selected.

SPECIFICATIONS

| | |
|---------------------------|-----------------------------|
| Measurement Type | Imperial |
| Bearing Rating | 10,000 rpm |
| Bearing Type | Dual Ball Bearings |
| Heavy Duty Thrust Bearing | No |
| Incremental Adjustment | 0.0005 in |
| Shaft Travel | 0.15 in |
| Cutter Thread | 1/4-28 |
| Shaft | Tri-Flat |
| Shaft Diameter | 1/4 in |
| Cutter Capacity | 1/2 in |
| Skirt | External Thread |
| Skirt Description | 0.813 in OD |
| Foot | Nylon |
| Solid Stop | Yes |
| Material | Steel |
| Stroke Length | 0.157 in (4mm) Shaft Travel |
| Country of Origin | USA |

ADDITIONAL IMAGES AND DRAWINGS

WES396 Series Microstop



Part Number

WES396-X-XX-XX-XX



Incremental Adjustment: 0.0005 in
 Material: Carbon Steel Body With
 Hardened Tool Steel Shaft

Bearing Rating: 10,000 rpm
 Bearing Type: Dual Ball-Bearings
 Dust Seal: Integrated Dust Seal
 Heavy Duty Thrust Bearing: No
 Solid Stop: Yes

| Code | Shaft Travel |
|---------|--------------|
| (Blank) | 0.157in |
| ES | 0.246in |

| Code | Cutter Thread |
|---------|---------------|
| (Blank) | 1/4-28 |
| 6 | M6x1 |

| Code | Foot Style |
|------|------------|
| N | Nylon |

| Code | Shaft Option |
|---------|-------------------------|
| (Blank) | 1/4in Standard Round |
| TF | Tri Flat |
| QC | Quick Change |
| TS | 1/4-28in Threaded Shank |

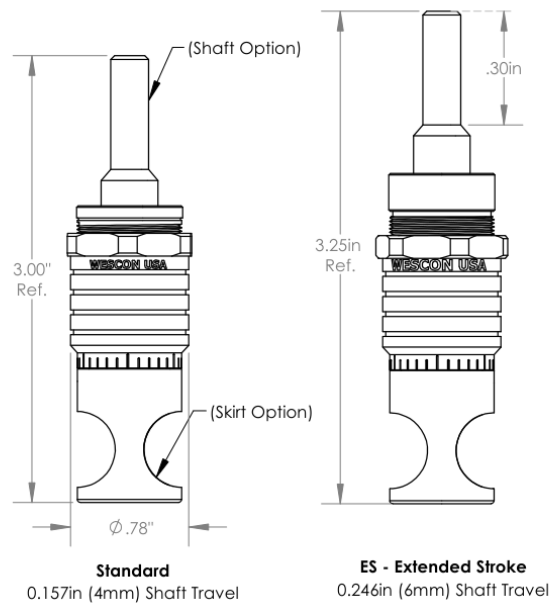

*For Skirt options see next page and website.



Part Number

WES396

Do not modify, copy, distribute, or reproduce this drawing without prior written authorization.

© 2025 Wescon Industries Inc.
 601 Century Plaza Dr. Houston, TX 77073, US
 www.wesconusa.com

Wescon 396 Microstop

Revision 10

All dimensions are in Inches

Information in this drawing is provided for reference only

Image 1

Skirt Option



S
Straight
Cutter $\phi 1/2"$ ($\phi 12\text{mm}$)



I
Internal Thread*
Cutter $\phi 7/16"$ ($\phi 11\text{mm}$)



E
External Thread*
Cutter $\phi 1/2"$ ($\phi 12\text{mm}$)



S2L
2-Leg
Cutter $\phi 1/2"$ ($\phi 12\text{mm}$)



SL
Slotted
Cutter $\phi 1/2"$ ($\phi 12\text{mm}$)



SI
Slotted Internal Thread*
Cutter $\phi 7/16"$ ($\phi 11\text{mm}$)



SE
Slotted External Thread*
Cutter $\phi 1/2"$ ($\phi 12\text{mm}$)



S3L
3-Leg
Cutter $\phi 1/2"$ ($\phi 12\text{mm}$)



WVS
Vacuum Straight
Cutter $\phi 1/2"$ ($\phi 12\text{mm}$)



WVI
Vacuum Internal Thread*
Cutter $\phi 7/16"$ ($\phi 11\text{mm}$)



WVE
Vacuum External Thread*
Cutter $\phi 1/2"$ ($\phi 12\text{mm}$)



SCA
Straight Cutaway
Cutter $\phi 1/2"$ ($\phi 12\text{mm}$)



SVS
Slotted Vacuum Straight
Cutter $\phi 1/2"$ ($\phi 12\text{mm}$)



SVI
Slotted Vacuum Internal Thread*
Cutter $\phi 7/16"$ ($\phi 11\text{mm}$)



SVE
Slotted Vacuum External Thread*
Cutter $\phi 1/2"$ ($\phi 12\text{mm}$)

*Select foot style from table

Revision 10

Do not modify, copy, distribute, or reproduce this drawing without prior written authorization.

All dimensions are in Inches



© 2025 Wescon Industries Inc.
601 Century Plaza Dr. Houston, TX 77073, US
www.wesconusa.com

Information in this drawing is provided for reference only

Part Number

WES396

Wescon 396 Microstop

Image 2



| Part Number | Material |
|-------------|----------|
| 39631-N | Nylon |
| 39631-S | Steel |
| 39631-P | Phenolic |

Foot Style For External Thread



| Part Number | Material |
|-------------|----------|
| 39620-N | Nylon |
| 39620-S | Steel |
| 39620-P | Phenolic |

Foot Style For Internal Thread



Part Number

WES396

Do not modify, copy, distribute, or reproduce this drawing without prior written authorization.

© 2025 Wescon Industries Inc.
601 Century Plaza Dr. Houston, TX 77073, US
www.wesconusa.com

Wescon 396 Microstop

Revision 10

All dimensions are in Inches

Information in this drawing is provided for reference only

Image 3