

DATASHEET

PART NUMBER

WES596-EXA-EN

**Wescon 596-EXA Extended Adjustment
Microstop - 1/4-28 - 3/4" Cutter Capacity -
External Nylon Foot**

Extended skirt adjustment of .750 in for variable length cutters.

WEBSITE

<https://www.wesconusa.com/products/WES596-EXA-EN>



The Wescon 596-EXA Extended Adjustment Series Microstop features an extended skirt adjustment of .750 inches, making it ideal for applications requiring variable length cutters. This versatile design allows you to easily go from a Countersink Cutter, to the use of a Threaded Shank Drill or Reamer, Drill-Countersink, and even a short Spot-Facing Cutter, along with most everything in between.

SPECIFICATIONS

Measurement Type	Imperial
Bearing Rating	10,000 rpm
Bearing Type	Dual Ball Bearings
Heavy Duty Thrust Bearing	Yes
Incremental Adjustment	0.0005 in
Shaft Travel	0.300 in
Dust Seal	Integrated Dust Seal
Cutter Thread	1/4-28
Shaft	Round
Shaft Diameter	1/4 in
Cutter Capacity	3/4 in
Skirt	External Thread
Skirt Description	1-1/4 in OD 3/4 in Cutter Capacity
Foot	Nylon
Solid Stop	Yes

Material	Steel
Country of Origin	USA

ADDITIONAL IMAGES AND DRAWINGS

WES596 Extended Adjustment Series Microstop



Part Number
WES596-EXA-XX-XX

- └─ Shaft Option
- └─ Foot Style
- └─ Skirt Option*

Extended skirt adjustment of .75 for variable length cutters

Code	Foot Style
N	Nylon
S	Steel
P	Phenolic

Code	Shaft Option
(Blank)	1/4in Standard Round
QC	Quick Change
TF	Tri Flat

Incremental Adjustment: 0.0005 in
 Shaft Travel: 0.300 in
 Cutter Thread: 1/4-28 in
 Material: Carbon Steel Body with Hardened Tool Steel Shaft

Bearing Rating: 10,000 rpm
 Bearing Type: Dual Ball-Bearings
 Dust Seal: Integrated Dust Seal
 Heavy Duty Thrust Bearing: Yes
 Solid Stop: Yes

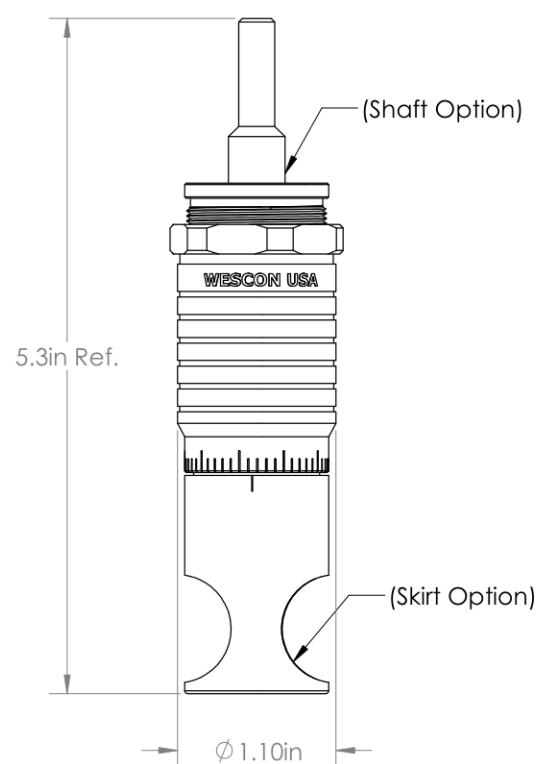

*For Skirt options see next page and website.

	Part Number WES596-EXA
Do not modify, copy, distribute, or reproduce this drawing without prior written authorization.	© 2025 Wescon Industries Inc. 601 Century Plaza Dr. Houston, TX 77073, US www.wesconusa.com
Revision 04 All dimensions are in Inches	Information in this drawing is provided for reference only
Wescon 596 Extended Adjustment Microstop	

Image 1

Skirt Option



Foot Style For External Thread

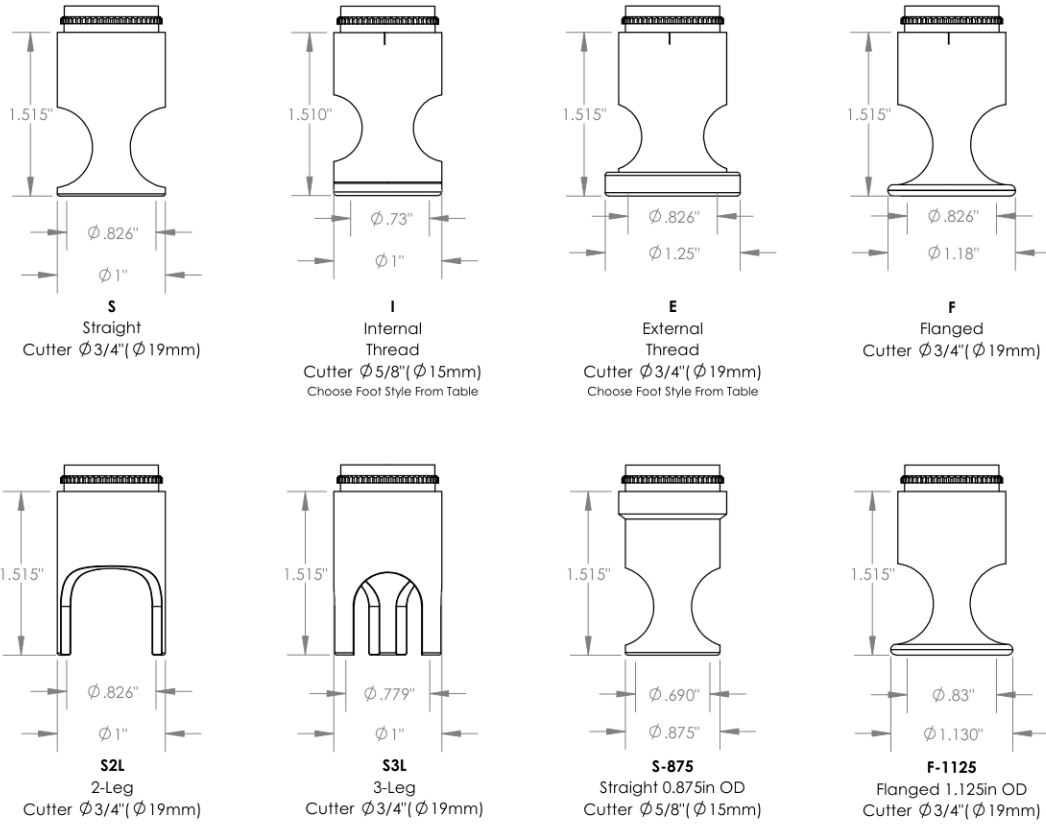
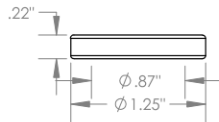

Part Number	Material
59631-N	Nylon
59631-S	Steel
59631-P	Phenolic

Foot Style For Internal Thread

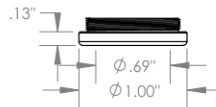

Part Number	Material
59620-N	Nylon
59620-S	Steel
59620-P	Phenolic



Part Number
WES596-EXA

Do not modify, copy, distribute, or reproduce this drawing without prior written authorization.

© 2025 Wescon Industries Inc.
601 Century Plaza Dr. Houston, TX 77073, US
www.wesconusa.com

Wescon 596 Extended Adjustment Microstop

Revision 04 All dimensions are in inches Information in this drawing is provided for reference only

Image 2