

## DATASHEET

PART NUMBER

### WES596-EXA-S-875-TF

**Wescon 596-EXA Extended Adjustment  
Microstop - 1/4-28 - 5/8" Cutter Capacity -  
Straight 0.875 in OD**

Extended skirt adjustment of .750 in for variable length cutters.

WEBSITE

<https://www.wesconusa.com/products/WES596-EXA-S-875-TF>



\* The image represents the general look of the series. Actual product may vary based on options selected.

The Wescon 596-EXA Extended Adjustment Series Microstop features an extended skirt adjustment of .750 inches, making it ideal for applications requiring variable length cutters. This versatile design allows you to easily go from a Countersink Cutter, to the use of a Threaded Shank Drill or Reamer, Drill-Countersink, and even a short Spot-Facing Cutter, along with most everything in between.

## SPECIFICATIONS

Measurement Type	Imperial
Bearing Rating	10,000 rpm
Bearing Type	Dual Ball Bearings
Heavy Duty Thrust Bearing	Yes
Incremental Adjustment	0.0005 in
Shaft Travel	0.300 in
Dust Seal	Integrated Dust Seal
Cutter Thread	1/4-28
Shaft	Tri-Flat
Shaft Diameter	1/4 in
Cutter Capacity	5/8 in
Skirt	Straight 0.875 in OD
Skirt Description	0.875 in OD 5/8 in Cutter Capacity
Solid Stop	Yes

<b>Material</b>	Steel
<b>Country of Origin</b>	USA

**ADDITIONAL IMAGES AND DRAWINGS**

### WES596 Extended Adjustment Series Microstop



**Part Number**  
WES596-EXA-XX-XX

- Shaft Option
- Foot Style
- Skirt Option\*

Code	Foot Style
N	Nylon
S	Steel
P	Phenolic

  

Code	Shaft Option
(Blank)	1/4in Standard Round
QC	Quick Change
TF	Tri Flat

**Extended skirt adjustment of .75 for variable length cutters**

Incremental Adjustment: 0.0005 in  
 Shaft Travel: 0.300 in  
 Cutter Thread: 1/4-28 in  
 Material: Carbon Steel Body with Hardened Tool Steel Shaft

Bearing Rating: 10,000 rpm  
 Bearing Type: Dual Ball-Bearings  
 Dust Seal: Integrated Dust Seal  
 Heavy Duty Thrust Bearing: Yes  
 Solid Stop: Yes

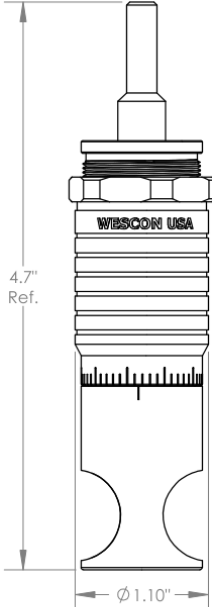

**WES596-EXA-S**  
Microstop with  
Ø 1/4" Standard Shaft

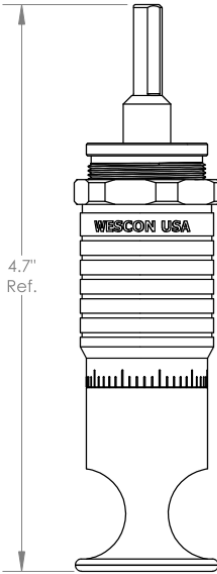

**WES596-EXA-F-TF**  
Microstop with  
Tri-Flat Shaft

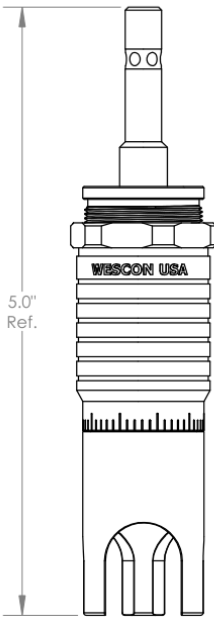

**WES596-EXA-S3L-QC**  
Microstop with  
Quick Change Shaft

\*For Skirt options see next page and website.



© 2025 Wescon Industries Inc.  
601 Century Plaza Dr. Houston, TX 77073, US  
www.wesconusa.com

Part Number

**WES596-EXA**

Wescon 596 Extended Adjustment  
Microstop

Revision 04

All dimensions are in Inches

Information in this drawing is provided for reference only

