

DATASHEET

PART NUMBER

WES596-EXA-S3L-QC

Wescon 596-EXA Extended Adjustment Microstop - 1/4-28 - 3/4" Cutter Capacity - 3-Leg

Extended skirt adjustment of .750 in for variable length cutters.

WEBSITE

<https://www.wesconusa.com/products/WES596-EXA-S3L-QC>



* The image represents the general look of the series. Actual product may vary based on options selected.

The Wescon 596-EXA Extended Adjustment Series Microstop features an extended skirt adjustment of .750 inches, making it ideal for applications requiring variable length cutters. This versatile design allows you to easily go from a Countersink Cutter, to the use of a Threaded Shank Drill or Reamer, Drill-Countersink, and even a short Spot-Facing Cutter, along with most everything in between.

SPECIFICATIONS

Measurement Type	Imperial
Bearing Rating	10,000 rpm
Bearing Type	Dual Ball Bearings
Heavy Duty Thrust Bearing	Yes
Incremental Adjustment	0.0005 in
Shaft Travel	0.300 in
Dust Seal	Integrated Dust Seal
Cutter Thread	1/4-28
Shaft	Quick Change
Shaft Diameter	1/4 in
Cutter Capacity	3/4 in
Skirt	3-Leg
Skirt Description	1 in OD 3/4 in Cutter Capacity
Solid Stop	Yes

Material	Steel
Country of Origin	USA

ADDITIONAL IMAGES AND DRAWINGS

WES596 Extended Adjustment Series Microstop



Part Number
WES596-EXA-XX-XX

— Shaft Option
— Foot Style
— Skirt Option*

Code	Foot Style
N	Nylon
S	Steel
P	Phenolic

Code	Shaft Option
(Blank)	1/4in Standard Round
QC	Quick Change
TF	Tri Flat

Extended skirt adjustment of .75 for variable length cutters

Incremental Adjustment: 0.0005 in
 Shaft Travel: 0.300 in
 Cutter Thread: 1/4-28 in
 Material: Carbon Steel Body with Hardened Tool Steel Shaft

Bearing Rating: 10,000 rpm
 Bearing Type: Dual Ball-Bearings
 Dust Seal: Integrated Dust Seal
 Heavy Duty Thrust Bearing: Yes
 Solid Stop: Yes

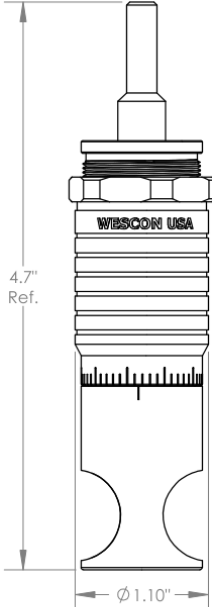

WES596-EXA-S
Microstop with
Ø 1/4" Standard Shaft

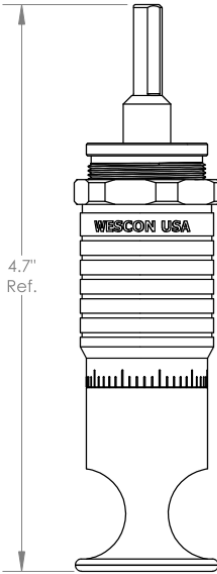

WES596-EXA-F-TF
Microstop with
Tri-Flat Shaft

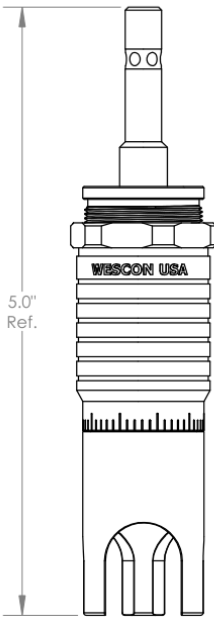

WES596-EXA-S3L-QC
Microstop with
Quick Change Shaft

*For Skirt options see next page and website.



© 2025 Wescon Industries Inc.
601 Century Plaza Dr. Houston, TX 77073, US
www.wesconusa.com

Part Number

WES596-EXA

Wescon 596 Extended Adjustment
Microstop

Revision 04

All dimensions are in Inches

Information in this drawing is provided for reference only

