

DATASHEET

PART NUMBER

WES598-VIS-TF

**Wescon 598 Microstop - 1/4-28 - 5/8" Cutter
Capacity - Vacuum Internal Thread Skirt - Steel
Foot**

10 DEGREE PIVOTING SHAFT (SWIVEL SHAFT) / HIGH
SPEED HEAVY DUTY

WEBSITE

<https://www.wesconusa.com/products/WES598-VIS-TF>

* The image represents the general look of the series. Actual product may vary based on options selected.

SPECIFICATIONS

Measurement Type	Imperial
Bearing Rating	10,000 rpm
Bearing Type	Dual Ball Bearings
Heavy Duty Thrust Bearing	Yes
Incremental Adjustment	0.0005 in
Shaft Travel	0.300 in
Dust Seal	Integrated Dust Seal
Cutter Thread	1/4-28
Shaft	Tri-Flat - Pivoting / Swivel Shaft
Shaft Diameter	1/4 in
Cutter Capacity	5/8 in
Skirt	Vacuum Internal Thread
Skirt Description	1 in OD 5/8 in Cutter Capacity
Foot	Steel
Solid Stop	Yes
Material	Steel
Vacuum Adapter	Yes

Country of Origin

USA

ADDITIONAL IMAGES AND DRAWINGS

WES598 Series Microstop



Part Number
WES 598-X-XX-XX

- Shaft Option
- Foot Style
- Skirt Option*
- Cutter Thread

Incremental Adjustment: 0.0005 in
 Shaft Travel: 0.300 in
 Material: Carbon Steel Body with Hardened Tool Steel Shaft

Bearing Rating: 10,000 rpm
 Bearing Type: Dual Ball-Bearings
 Dust Seal: Integrated Dust Seal
 Heavy Duty Thrust Bearing: Yes
 Solid Stop: Yes

Code	Cutter Thread
(Blank)	1/4-28
6	M6x1
8	M8x1

Code	Foot Style
N	Nylon
S	Steel
P	Phenolic

Code	Shaft Option
(Blank)	Round Swivel Shaft
QC	Quick Change Swivel Shaft
TF	Tri Flat Swivel Shaft

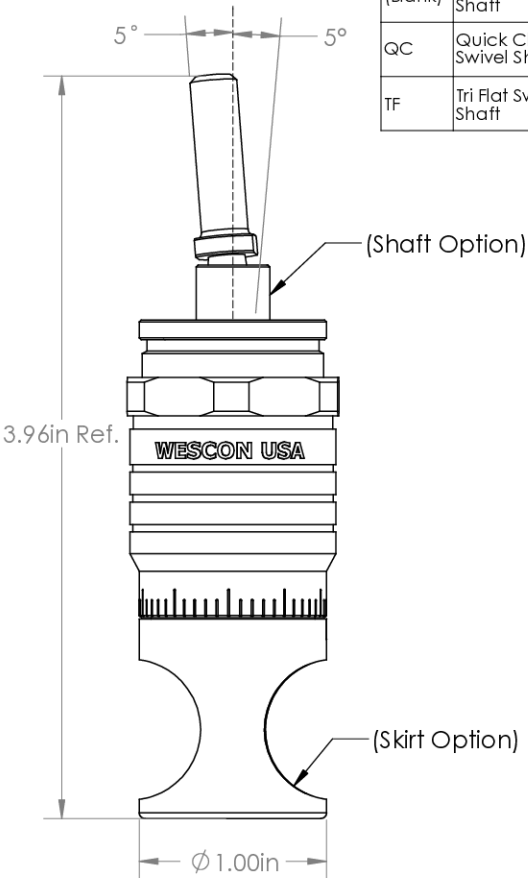

5° 5°

3.96in Ref.

(Shaft Option)

(Skirt Option)

Ø 1.00in

*For Skirt options see next page and website.



WESCON

© 2025 Wescon Industries Inc.
 601 Century Plaza Dr. Houston, TX 77073, US
 www.wesconusa.com

Part Number **WES598**

Wescon 598 Microstop

Revision 05

All dimensions are in inches

Information in this drawing is provided for reference only

Image 1

Skirt Option (Continuation)



F
Flanged
Cutter $\phi 3/4"$ ($\phi 19$ mm)

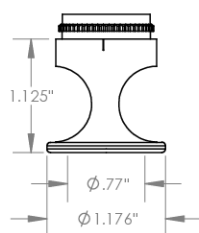

FH
Flanged High
Cutter $\phi 3/4"$ ($\phi 19$ mm)



SF
Spherical Flanged
Cutter $\phi 3/4"$ ($\phi 19$ mm)



F-1125
Flanged 1.125 in OD
Cutter $\phi 3/4"$ ($\phi 19$ mm)



C
Close Quarters
Cutter $\phi 3/8"$ ($\phi 10$ mm)



F2L
Flanged 2-Leg
Cutter $\phi 3/4"$ ($\phi 19$ mm)



S2L
2-Leg
Cutter $\phi 3/4"$ ($\phi 19$ mm)



S3L
3-Leg
Cutter $\phi 3/4"$ ($\phi 19$ mm)



WVI
Vacuum Internal Thread
Cutter $\phi 5/8"$ ($\phi 15$ mm)



WVE
Vacuum External Thread
Cutter $\phi 3/4"$ ($\phi 19$ mm)



SVI
Slotted Vacuum External Thread
Cutter $\phi 5/8"$ ($\phi 15$ mm)



SVE
Slotted Vacuum External Thread
Cutter $\phi 3/4"$ ($\phi 19$ mm)



Part Number

WES598

Do not modify, copy, distribute, or reproduce this drawing without prior written authorization.

© 2025 Wescon Industries Inc.
601 Century Plaza Dr. Houston, TX 77073, US
www.wesconusa.com

Wescon 598 Microstop

Revision 05

All dimensions are in inches

Information in this drawing is provided for reference only

Image 2

Skirt Option



Continued In Next Page.

Revision 05

Do not modify, copy, distribute, or reproduce this drawing without prior written authorization.

All dimensions are in inches



© 2025 Wescon Industries Inc.
601 Century Plaza Dr. Houston, TX 77073, US
www.wesconusa.com

Information in this drawing is provided for reference only

Part Number

WES598

Wescon 598 Microstop

Image 3

**Foot Style
For External Thread**



Part Number	Material
59631-N	Nylon
59631-S	Steel
59631-P	Phenolic

**Foot Style
For Internal Thread**



Part Number	Material
59620-N	Nylon
59620-S	Steel
59620-P	Phenolic

**Foot Style
For Bell External Thread**



Part Number	Material
59641-N	Nylon
59641-S	Steel
59641-P	Phenolic

**Foot Style
For Bell Internal Thread**



Part Number	Material
59640-N	Nylon
59640-S	Steel
59640-P	Phenolic

**Foot Style
For Bell Wide External Thread**



Part Number	Material
59651-N	Nylon
59651-S	Steel
59651-P	Phenolic



Part Number **WES598**

Do not modify, copy, distribute, or reproduce this drawing without prior written authorization.

© 2025 Wescon Industries Inc.
601 Century Plaza Dr. Houston, TX 77073, US
www.wesconusa.com

Wescon 598 Microstop

Revision 04 All dimensions are in inches Information in this drawing is provided for reference only

Image 4