

## DATASHEET

PART NUMBER

**WES696-1000-S2L-4320-QC**

**Wescon 696 Microstop - 7/16-20 - 1" Cutter  
Capacity - 2-Leg Skirt**

LARGE CAPACITY UNITS FOR STEEL, ALUMINUM &  
COMPOSITES

WEBSITE

<https://www.wesconusa.com/products/WES696-1000-S2L-4320-QC>



\* The image represents the general look of the series. Actual product may vary based on options selected.

## SPECIFICATIONS

<b>Measurement Type</b>	Imperial
<b>Bearing Rating</b>	10,000 rpm
<b>Bearing Type</b>	Dual Ball-Bearings
<b>Heavy Duty Thrust Bearing</b>	Yes
<b>Incremental Adjustment</b>	0.0005 in
<b>Shaft Travel</b>	1/2 in
<b>Dust Seal</b>	Integrated Dust Seal
<b>Cutter Thread</b>	7/16-20
<b>Shaft</b>	Quick Change
<b>Shaft Diameter</b>	3/8 in
<b>Cutter Capacity</b>	1 in
<b>Skirt</b>	2-Leg
<b>Solid Stop</b>	Yes
<b>Material</b>	Steel
<b>Country of Origin</b>	USA

## ADDITIONAL IMAGES AND DRAWINGS

### WES696 Series Microstop

**Part Number**  
WES696-XX-XX-XX-XX

- Shaft Option
- Foot Style
- Skirt Option\*
- Cutter Capacity
- Shaft Thread

Code	Shaft Thread
Blank	3/8-24
4320	7/16-20
8	M8x1
10	M10x1

Code	Cutter Capacity
875	7/8"(22mm)
1000	1"(25mm)
1250	1-1/4"(32mm)
1375	1-3/8"(35mm)
1500	1-1/2"(38mm)
2000	2"(50.8mm)

Code	Foot Style
N	Nylon
S	Steel

  

Code	Shaft Option
(Blank)	Round
QC	Quick Change
TF	Tri Flat



Incremental Adjustment: 0.0005 in  
 Shaft Travel: 0.500 in  
 Material: Carbon Steel Body with Hardened Tool Steel Shaft

Bearing Rating: 10,000 rpm  
 Bearing Type: Dual Ball Bearings  
 Dust Seal: Integrated Dust Seal  
 Heavy Duty Thrust Bearing: Yes  
 Solid Stop: Yes

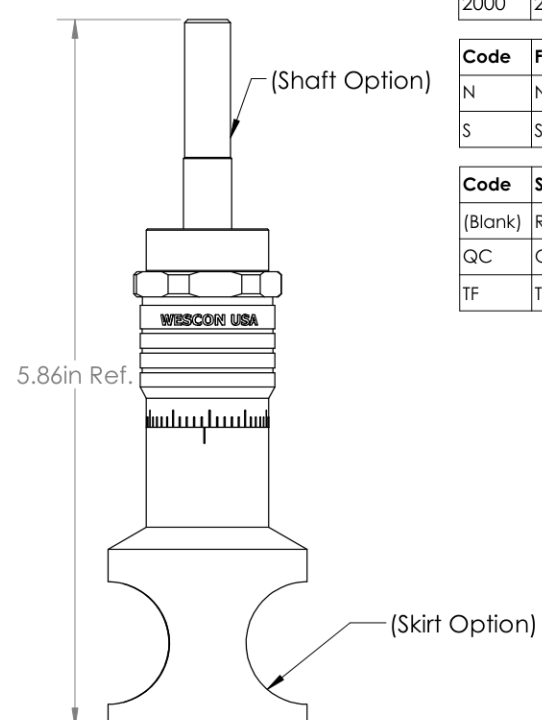

5.86in Ref.

(Shaft Option)

(Skirt Option)

\*For skirt options see next page and website.



**WESCON**

Part Number  
**WES696**

Revision 02

Do not modify, copy, distribute, or reproduce this drawing without prior written authorization.

© 2025 Wescon Industries Inc.  
 601 Century Plaza Dr. Houston, TX 77073. US  
 www.wesconusa.com

Information in this drawing is provided for reference only

Image 1

### Skirt Option



### Foot Style For External Thread



External Thread  
Choose Foot Style From Table



Part Number	Material
59631-N	Nylon
59631-S	Steel
59631-P	Phenolic

Code	Cutter Capacity	Ø A	OD for S,SCA,S2L & S3L		OD for E & SE
			Ø B	Ø C	Ø c
875	7/8"(22 mm)	7/8" (22 mm)	1-3/16" (30 mm)		1.317 (33 mm)
1000	1"(25 mm)	1-5/8" (42 mm)	1-7/8" (48 mm)		1.945 (49 mm)
1250	1-1/4"(32 mm)	1-1/2" (38 mm)	1-5/8" (42 mm)		1.755 (45 mm)
1375	1-3/8"(35 mm)	1-5/8" (42 mm)	1-7/8" (48 mm)		2.005 (50.8 mm)
1500	1-1/2"(38 mm)	1-1/2" (38 mm)	2" (50.8 mm)		2.130 (54 mm)
2000	2"(50.8 mm)	2-1/4" (58 mm)	2-1/2" (64 mm)		2.630 (67 mm)



Part Number

**WES696**

Do not modify, copy, distribute, or reproduce this drawing without prior written authorization.

© 2025 Wescon Industries Inc.  
601 Century Plaza Dr. Houston, TX 77073, US  
www.wesconusa.com

Wescon 696 Microstop

Revision 02

All dimensions are in inches

Information in this drawing is provided for reference only

Image 2